

# T4WM / TUBULAR 4-WAY MERCHANDISER

## ASY-569

### INSTALLATION INSTRUCTIONS

- 1** **OPTIONAL:** If using plate casters, secure plate casters to underside of platform with provided #12 x 1" screws. (4) per plate caster.
- 2** Secure bottom plate to center of platform using the provided (4) screws 1/4 - 20 x 3/4" through center holes as shown. **NOTE: The Bottom and Top Cap may already be attached. If so remove Top Cap and discard screws**
- 3** Stand frames 1 and 2 on plate as shown. Slide frame 2 up tight to frame 1 and *fasten frame 2 only* through the front plate holes with provided screws #10 x 3/4" as shown.
- 4** Stand frames 3 and 4 on plate. Slide all frames up tight and secure through front plate holes with provided hardware, #10 x 3/4" screws.
- 5** After all four frames are secured to the bottom plate, set top plate in place. Pull the four frames to the plate before fastening. Fasten the top plate with (8) provided self-drilling screws.

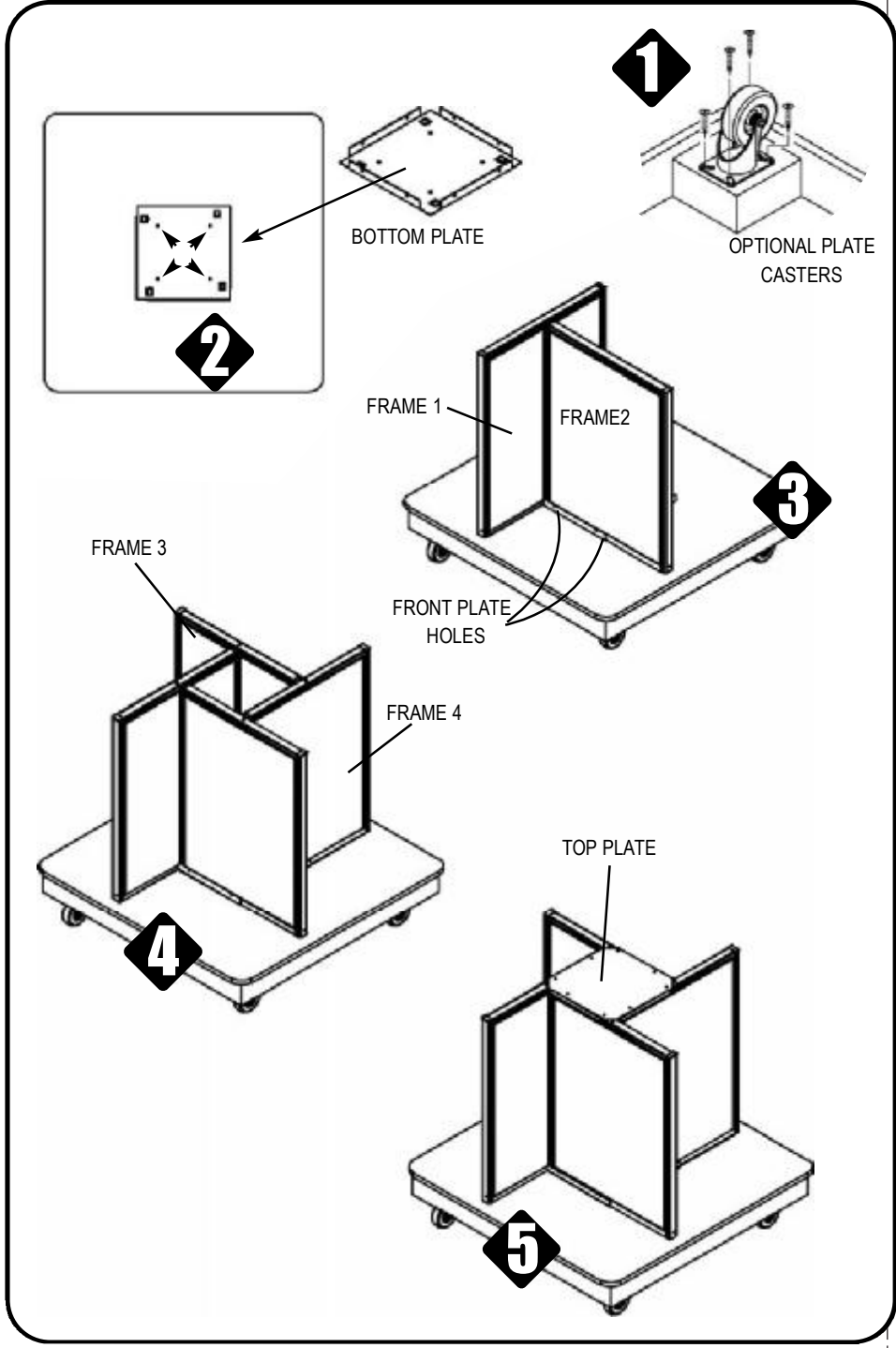

**ASSEMBLY COMPLETE**



P.O. BOX 729 / TERRELL, TEXAS 75160 / 972.563.5744 / 800.776.2349  
 P.O. BOX 177 / GOODWATER, ALABAMA 35072 / 205.839.6354 / 800.633.6282

**REV D**

REV#	ECN#	REVISION	BY	DATE	REV#	ECN#	REVISION	BY	DATE
01	5*4224	ADDED NOTE	CAB	11/30/07					